

Panasonic

Advanced Hybrid System

KX-TA624

Operating Instructions for the Voice Processing System (KX-TVP50)

In this manual, the suffix of each model number is omitted.

This manual explains how to set the KX-TA624 to work with the KX-TVP50, and what can be done with the KX-TVP50.

Please refer to the Installation Manual for the KX-TVP50 for details on setting the KX-TVP50.

Contents

Section 1 Installation

1.1	System Features	1-2
	Voice Mail Integration for KX-TVP50	1-2
	Live Call Screening (LCS)	1-7
	Two-Way Recording into Voice Mail.....	1-8
1.2	System Programming	1-9
	[130] Voice Mail 1 APT Port for KX-TVP50.....	1-9
	[131] Voice Mail 2 APT Port for KX-TVP50.....	1-10
	[620] Live Call Screening Recording Mode Assignment	1-11
	[963] Call Forwarding Selection	1-12
1.3	Programming Tables	1-13

Section 2 Operations

2.1	Proprietary Telephone Settings	2-2
	Customising the Buttons on Your Telephone	2-2
	Live Call Screening Mode Set	2-6
2.2	Telephone Features	2-7
	Live Call Screening (LCS)	2-7
	Two-Way Recording into Voice Mail.....	2-13
	Voice Mail Integration for KX-TVP50.....	2-15
	Voice Mail Transfer	2-18
2.3	Operator/Manager Service Features	2-19
	Live Call Screening Password Control	2-19
2.4	DSS Console Features	2-20
	Initial Settings.....	2-20
2.5	Display Examples.....	2-23

Section 1
Installation

1.1 System Features

Voice Mail Integration for KX-TVP50

When a Panasonic Voice Processing System (KX-TVP50) is connected to the system, they communicate in a tightly integrated fashion using APT Integration. For example, when the Voice Processing System (VPS) executes Auto Configuration using Quick Setup (PC required) or using DIP switch initialisation (PC is not required), the VPS reads data from the system to automatically create mailboxes for each extension and to set the VPS clock (date and time).

The system informs a VPS of the state of a call (busy, answered, ringing, disconnected, etc.) through APT Integration. The System also informs a VPS through APT Integration of the destination of a call transferred to the VPS by the Call Forwarding or DISA Intercept Routing — No Answer feature. APT Integration is established after System Programs [130] and/or [131] are executed and after the VPS performs Quick Setup (or DIP switch initialisation). See the KX-TVP50 Installation Manual for further details.

System Explanation

1. Voice Mail Service

1.1 Call Forwarding to VM

If an extension user sets Call Forwarding (C. FWD) to the VPS, an incoming call will be forwarded to the VPS. The system will send the VPS the extension mailbox number at that time. Therefore, the calling party can leave their message in the mailbox of the desired extension without knowing the mailbox number.

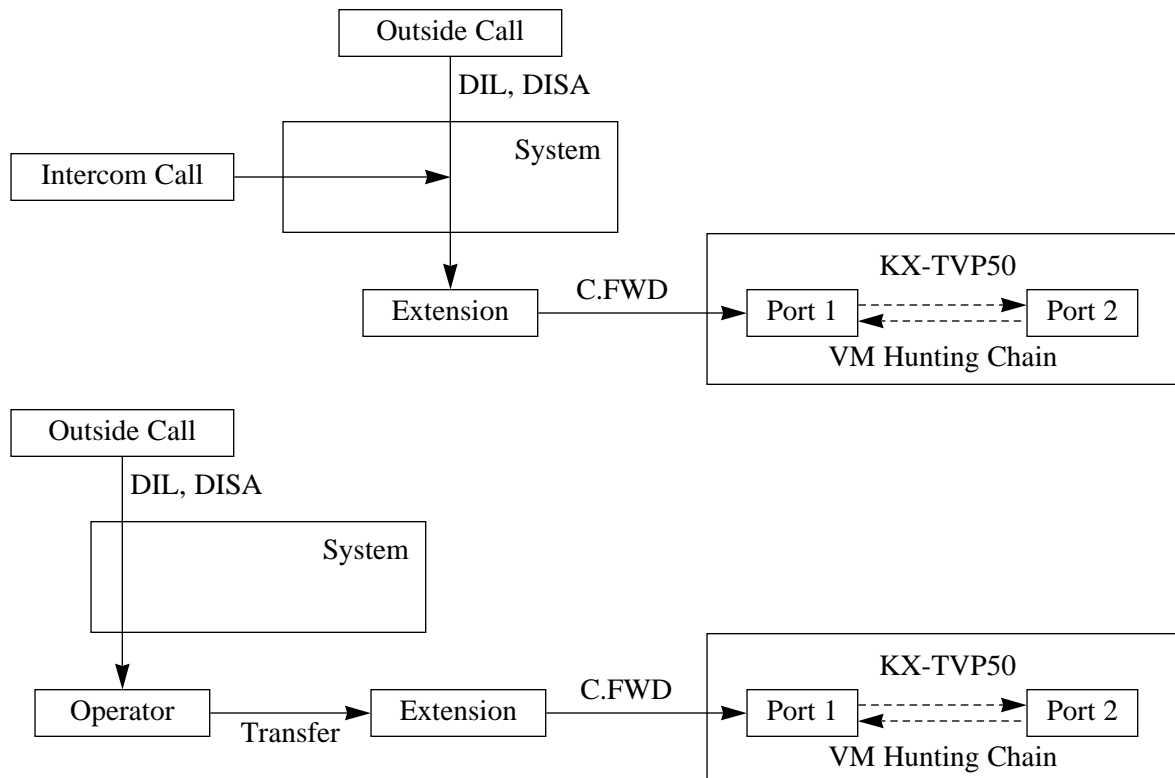

1.2 DISA Intercept to VM

If the VPS is set as the Intercept destination of an exchange line, an outside call will be forwarded to the VPS. The system sends the VPS the extension mailbox number at that time. Therefore, the calling party can leave their message in the mailbox of the desired extension without knowing the mailbox number. Delayed Ringing must be assigned to Voice Mail extensions in programs [411]–[413].

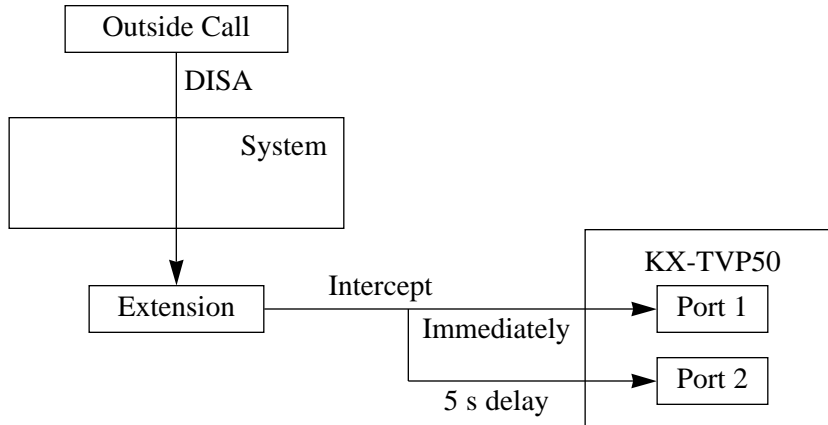

1.3 Special Features for a Proprietary Telephone through APT Integration

The following features are available only with a proprietary telephone in APT Integration.

- Live Call Screening (LCS)
- Two-Way Recording into Voice Mail
- Voice Mail Transfer

With these features, a proprietary telephone user can monitor incoming messages being recorded into their mailbox, or easily record a conversation in their or a specified mailbox, or easily transfer outside calls to a desired extension mailbox.

1.4 Listening to a Recorded Message

If the VPS receives a message or records a conversation, the VPS can turn on the MESSAGE button indicator on the corresponding proprietary telephone to notify the user. The VPS notifies the extension user that there is a message waiting in their mailbox. When the MESSAGE button indicator is lit, pressing the button allows the extension user to play back the stored message. A single line telephone user hears dial tone 3 when going off-hook if there are messages in their mailbox. They can call the Voice Mail extension to listen to their messages. In this case, they must listen to all of the messages. Once they access voice mail, dial tone 3 will be eliminated and not be heard next time they go off-hook. Therefore, they will not know even if there are messages left.

1.1 System Features

2. Automated Attendant (AA) Service

2.1 AA to Extension

AA receives and answers outside calls and offers services such as transferring to an extension or mailbox using DTMF signaling from the calling party.

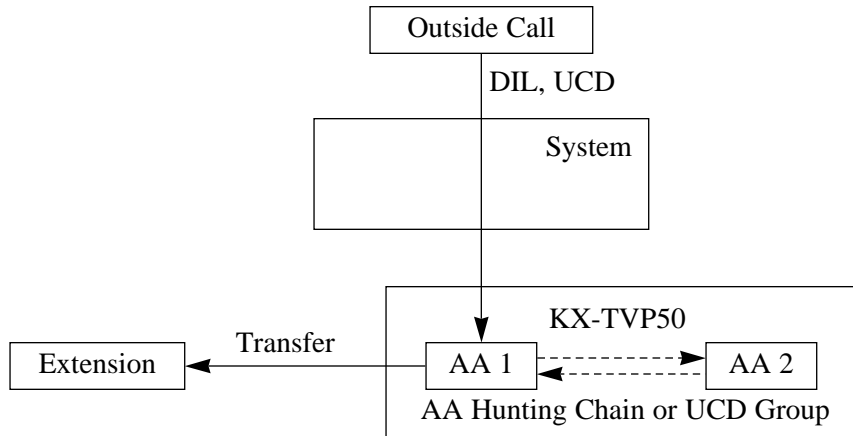

2.2 Extension Backup

If the Voice Mail extensions are assigned to ring with other extensions, for example the operator extension, for the same exchange line, Voice Mail extensions can be used as backup for the operator when the operator cannot answer an incoming outside call. Delayed Ringing must be assigned to Voice Mail extensions.

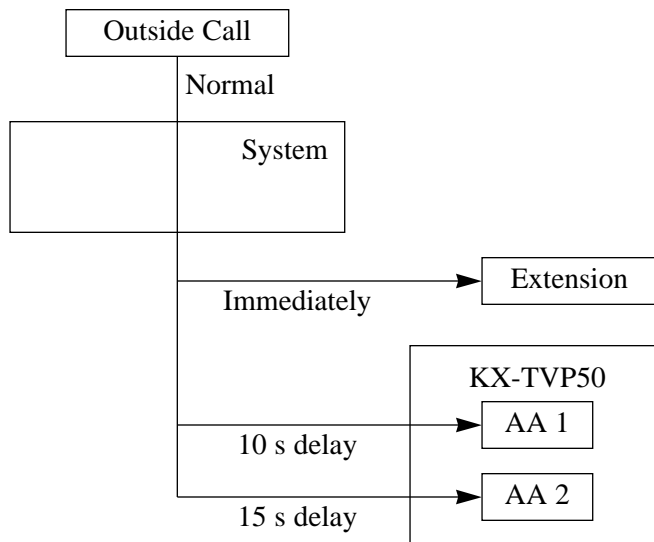



- A maximum of 2 VPSs can be connected to the system. When 2 VPSs are connected to the system, keep in mind that each extension can have only 1 mailbox — but when the VPSs have executed Auto Configuration, an extension has a mailbox in both VPSs. Therefore, you must delete a mailbox in either VPS so that there are no duplicates. See the KX-TVP50 Installation Manual for further details.

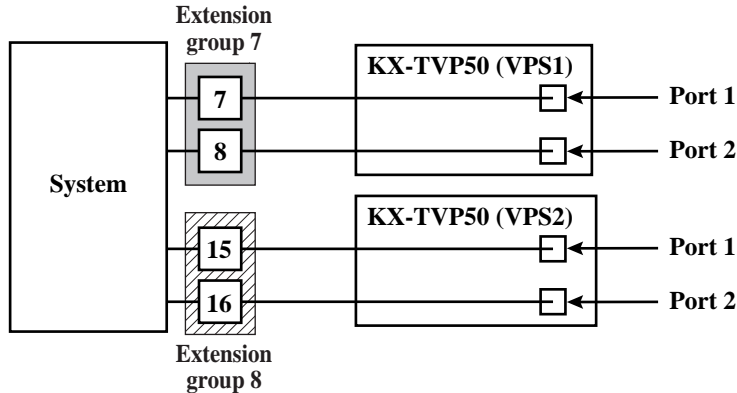

- A maximum of 4 extension ports (07, 08, 15 and 16) of the system can be connected to VPSs with 4-conductor wire. Extension port 07, or ports 07 and 08 can be the Voice Mail APT ports for VPS1 in program [130]. Extension port 15, or ports 15 and 16 can be for VPS2 in program [131].
- When “Port 7 & 8” is selected in program [130], extension ports 07 and 08 will be in extension group 7 automatically. Likewise, when “Port 15 & 16” is selected in program [131], extension ports 15 and 16 will be in extension group 8 automatically. Also the Extension Hunting type is set as “Circular”, and the VM Hunting Chain and AA Hunting Chain are enabled automatically in each of these 2 extension groups.
- The lowest port (07 or 15) of each extension group must be connected to the Port 1 of a VPS. The VPS data is transmitted to the VPS via the Port 1.
- One connection between the system and a VPS, for example extension port 07 of the system and Port 1 of the VPS, creates 1 Voice Mail extension and can only answer 1 call. Therefore, if 1 VPS is connected to the system, maximum of 2 calls can be answered simultaneously.
- A VPS can be assigned as the destination for the following features.
 - Call Forwarding – All Calls
 - Call Forwarding – Busy/No Answer
 - DISA Intercept Routing – No Answer

For these features, the caller does not need to know the mailbox number of the called extension because the code is automatically transmitted to the VPS. If a DISA call is transferred to the VPS by Intercept Routing from a DISA ring group, the system will transmit the mailbox number of the lowest port number of the DISA ring group.
- Data Line Security is set automatically on the Voice Mail extension.

1.1 System Features



- **Connection Reference**
 - Section 2, Installation Installation Manual
 - 2.8 Extension Connection
- **Required Programming**
 - 1.2 System Programming
 - [130] Voice Mail 1 APT Port for KX-TVP50
 - [131] Voice Mail 2 APT Port for KX-TVP50
 - [963] Call Forwarding Selection
 - Section 4, System Programming Installation Manual
 - [009] Extension Number Assignment
 - [100] Hunting Group Set
 - [101] Hunting Type
 - [408]–[410] Flexible Ringing Assignment — Day/Night/Lunch
 - [411]–[413] Delayed Ringing Assignment — Day/Night/Lunch
 - [414]–[416] Exchange Line Mode — Day/Night/Lunch
 - [507] DISA Intercept Mode
 - [600] Extension Group Assignment
 - Section 1, Operations Operating Instructions
 - 1.2 Proprietary Telephone Settings
 - “Customising the Buttons on Your Telephone”, Restoring the MESSAGE Button
- **Related Feature References**
 - 1.1 System Features
 - Live Call Screening (LCS)
 - Two-Way Recording into Voice Mail
 - Section 3, Features Installation Manual
 - Call Forwarding
 - Data Line Security
 - Direct Inward System Access (DISA)
 - Distinctive Dial Tones
 - Extension Hunting
 - Intercept Routing
- **Operation References**
 - 2.2 Telephone Features
 - “Live Call Screening (LCS)”
 - “Two-Way Recording into Voice Mail”
 - “Voice Mail Integration for KX-TVP50”
 - “Voice Mail Transfer”

Live Call Screening (LCS)

Allows a proprietary telephone user to monitor their voice mailbox while an incoming caller is leaving a message and, if desired, intercept the call. The voice mailbox can be monitored in one of 2 ways — Hands-free mode or Private mode.

Hands-free Mode: A message can be monitored automatically through the telephone speaker at the same time.

Private Mode: An alert tone will be heard while the caller is leaving a message.

Alert tone

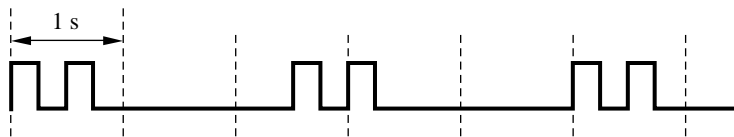

To intercept the call in either Hands-free or Private mode, press the SP-PHONE button or the LCS button.



- When the extension user is having a conversation, a Call Waiting tone will be heard if Call Waiting has been enabled. The user can put the existing call on hold before accessing LCS.
- A flexible line key or DSS (Direct Station Selection) button can be assigned as a Live Call Screening (LCS) button.
- To prevent unauthorised monitoring, a 3-digit password must be set by the LCS user. If the user forgets their password, it can be cleared by the operator or manager.
- Each extension can be programmed to either close the mailbox or keep recording the conversation after the call is intercepted.



• **Required Programming**

1.2 System Programming

 [620] Live Call Screening Recording Mode Assignment

2.1 Proprietary Telephone Settings

 “Customising the Buttons on Your Telephone”, Live Call Screening (LCS) Button

Live Call Screening (LCS) Cancel Button

 “Live Call Screening Mode Set”

2.4 DSS Console Features

 “Initial Settings”, Live Call Screening (LCS) Button Assignment

Live Call Screening (LCS) Cancel Button Assignment

• **Operation Reference**

2.2 Telephone Features

 “Live Call Screening (LCS)”

1.1 System Features

Two-Way Recording into Voice Mail

Allows a proprietary telephone user to record a conversation into their mailbox or another mailbox, while talking on the phone.

Note:

When you record Two-Way telephone conversations, you should inform the other party that the conversation is being recorded.

Use the Two-Way Record button to record into your own mailbox. Use the Two-Way Transfer button to record into someone else's mailbox.



- A flexible line key or DSS (Direct Station Selection) button can be assigned as the Two-Way Record button or the Two-Way Transfer button.
- When all of the Voice Mail ports are busy, pressing the Two-Way Record button sends an alarm tone.
- When all of the Voice Mail ports are busy, pressing the Two-Way Transfer button followed by an extension number sends an alarm tone.



- **Required Programming**

- 2.1 **Proprietary Telephone Settings**

- “Customising the Buttons on Your Telephone”, Two-Way Record button
Two-Way Transfer button

- 2.4 **DSS Console Features**

- “Initial Settings”, Two-Way Record Button Assignment
Two-Way Transfer Button Assignment

- **Operation Reference**

- 2.2 **Telephone Features**

- “Two-Way Recording into Voice Mail”

[130] Voice Mail 1 APT Port for KX-TVP50

Enables or disables the extension ports 07, or 07 and 08 corresponding to the Voice Mail APT ports for data transmission to the Panasonic Voice Processing System (KX-TVP50).

1 **3** **0** **NEXT** **SELECT** **STORE** **END**

(Port 7/
Port 7 & 8/
Disable)

Default All extension ports – Disable



- To change the current assignment from “Port 7” to “Port 7 & 8”, first it must be changed to “Disable”. Likewise, to change it from “Port 7 & 8” to “Port 7”, first it must be changed to “Disable”. If the current assignment is already “Disable”, making a change can be done in 1 step.
- When “Port 7 & 8” is selected in this program, following programs are automatically set as described below.
 - [600] Extension Group Assignment:
 - extension port 07 — extension group 7
 - extension port 08 — extension group 7
 - [100] Hunting Group Set: extension group 7 — Enable
 - [101] Hunting Type: extension group 7 — Circular
 - [102] Voice Mail Port for KX-TVP100:
 - extension port 07 — Enable
 - extension port 08 — Enable
- If “Enable” is assigned in program [103] “DTMF Integration for KX-TVP100”, “Port 7” or “Port 7 & 8” cannot be selected.
- The extension ports assigned as the Voice Mail APT ports in this program are automatically set the Data Line Security.



- **Related Feature Reference**

- 1.1 System Features

- Voice Mail Integration for KX-TVP50

1.2 System Programming

[131] Voice Mail 2 APT Port for KX-TVP50

Enables or disables the extension ports 15, or 15 and 16 corresponding to the Voice Mail APT ports for data transmission to the Panasonic Voice Processing System (KX-TVP50).



(Port 15/
Port 15 & 16/
Disable)

Default All extension ports – Disable



- To change the current assignment from “Port 15” to “Port 15 & 16”, first it must be changed to “Disable”. Likewise, to change it from “Port 15 & 16” to “Port 15”, first it must be changed to “Disable”. If the current assignment is already “Disable”, making a change can be done in 1 step.
- When “Port 15 & 16” is selected in this program, following programs are automatically set as described below.
 - [600] Extension Group Assignment:
 - extension port 15 — extension group 8
 - extension port 16 — extension group 8
 - [100] Hunting Group Set: extension group 8 — Enable
 - [101] Hunting Type: extension group 8 — Circular
 - [102] Voice Mail Port for KX-TVP100:
 - extension port 15 — Enable
 - extension port 16 — Enable
- If “Enable” is assigned in program [103] “DTMF Integration for KX-TVP100”, “Port 15” or “Port 15 & 16” cannot be selected.
- The extension ports assigned as the Voice Mail APT ports in this program are automatically set the Data Line Security.



• **Related Feature Reference**

- 1.1 System Features
 - Voice Mail Integration for KX-TVP50

[620] Live Call Screening Recording Mode Assignment

Assigns whether to close the mailbox or keep recording the conversation after a call is intercepted.

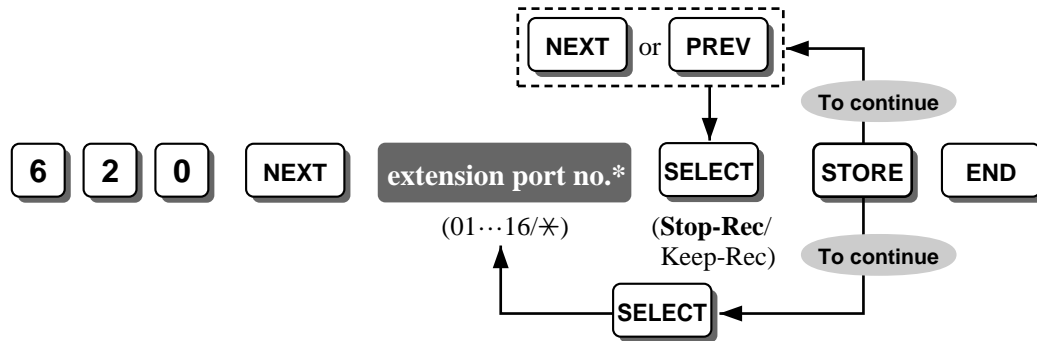

* Extension port number: 01 through 16 / * (All extension ports)

Default All extension ports – Stop-Rec (Stop recording)



• **Related Feature References**

- 1.1 System Features
- Live Call Screening (LCS)

1.2 System Programming

[963] Call Forwarding Selection

Enables or disables the Call Forwarding feature for each extension for an outside call via an exchange line assigned “Normal” in programs [414]–[416] “Exchange Line Mode — Day/Night/Lunch”. If disabled, an extension user cannot forward the outside call even if the user has set the Call Forwarding feature.

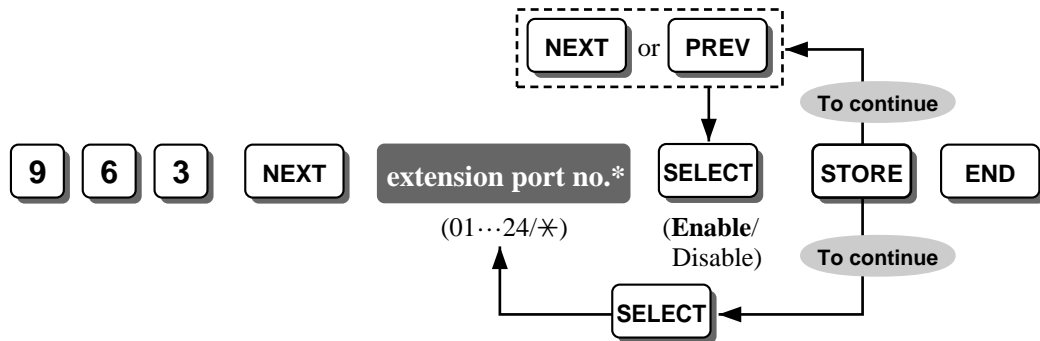

* Extension port number: 01 through 24 / * (All extension ports)

Default All extension ports – Enable



- If set to “Disable” for an extension whose Call Forwarding destination is a Voice Processing System (VPS) and the extension has been assigned to ring with other extensions, for example, it can prevent the VPS from receiving a call before other extensions receive it.



• **Related Feature Reference**

Section 3, Features Installation Manual
Call Forwarding

	[130] Voice Mail 1 APT Port for KX-TVP50			[131] Voice Mail 2 APT Port for KX-TVP50		
	Port 7	Port 7 & 8	Disable	Port 15	Port 15 & 16	Disable
Selection			✓			✓
Default						
Change						

	[620] Live Call Screening Recording Mode Assignment		[963] Call Forwarding Selection	
	Selection		Selection	
Extension port no.	Stop-Rec	Keep-Rec	Enable	Disable
Default: All	✓		✓	
01				
02				
03				
04				
05				
06				
07				
08				
09				
10				
11				
12				
13				
14				
15				
16				
17				
18				
19				
20				
21				
22				
23				
24				
*				

Section 2
Operations

2.1 Proprietary Telephone Settings

Customising the Buttons on Your Telephone

Live Call Screening (LCS) Button (Assignment)

Allows you to assign a Flexible line key as the Live Call Screening (LCS) button.

— Be sure the handset is on the cradle and the SP-PHONE button is off. To program, set the MEMORY switch to “PROGRAM” or press the PROGRAM button.

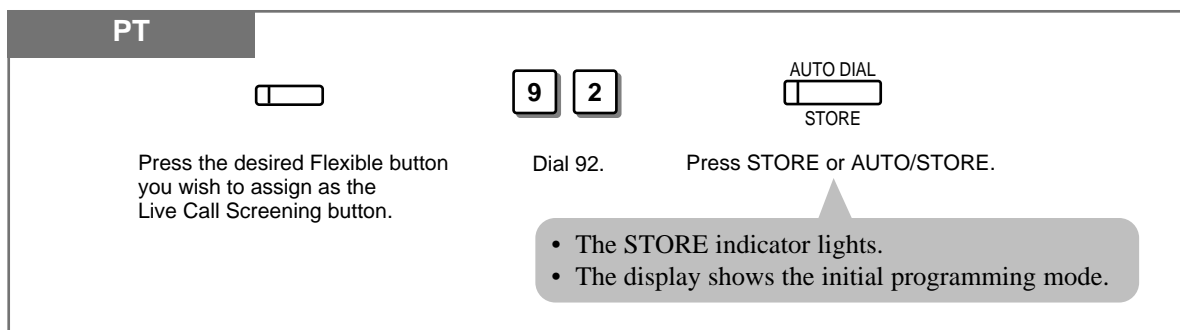

— After programming, set the MEMORY switch to “SET” or press the PROGRAM button.



- **Related Feature Reference**
2.2 Telephone Features
“Live Call Screening (LCS)”

Live Call Screening (LCS) Cancel Button (Assignment)

Allows you to assign a Flexible line key as the Live Call Screening (LCS) Cancel button.

— Be sure the handset is on the cradle and the SP-PHONE button is off. To program, set the MEMORY switch to “PROGRAM” or press the PROGRAM button.

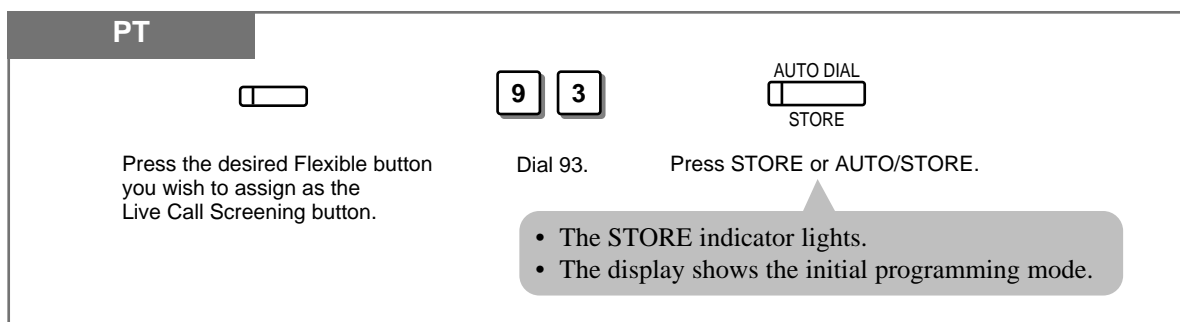

— After programming, set the MEMORY switch to “SET” or press the PROGRAM button.



- **Related Feature Reference**
2.2 Telephone Features
“Live Call Screening (LCS)”

Two-Way Record Button (Assignment)

Allows you to assign a Flexible line key as the Two-Way Record button. This allows you to record a conversation into your voice mailbox.

— Be sure the handset is on the cradle and the SP-PHONE button is off. To program, set the MEMORY switch to “PROGRAM” or press the PROGRAM button.

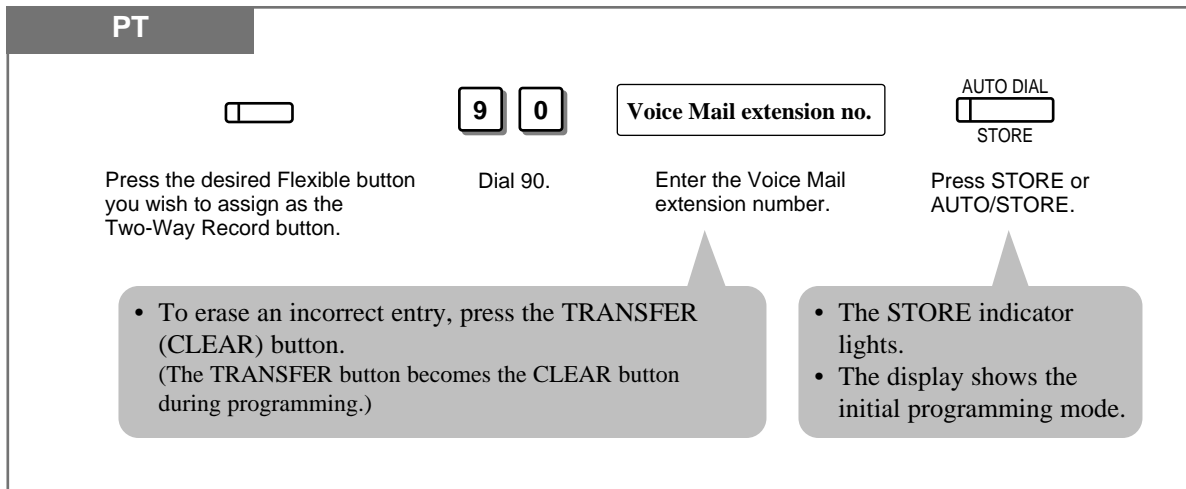

— After programming, set the MEMORY switch to “SET” or press the PROGRAM button.



- You cannot enter a non-existent extension number.
- A Voice Mail extension number must be assigned by System Programming.



- Related Feature Reference**
 - 2.2 Telephone Features
 - “Two-Way Recording into Voice Mail”

2.1 Proprietary Telephone Settings

Two-Way Transfer Button (Assignment)

Allows you to assign a Flexible line key as the Two-Way Transfer button. This allows you to record a conversation into a desired mailbox.

— Be sure the handset is on the cradle and the SP-PHONE button is off. To program, set the MEMORY switch to “PROGRAM” or press the PROGRAM button.

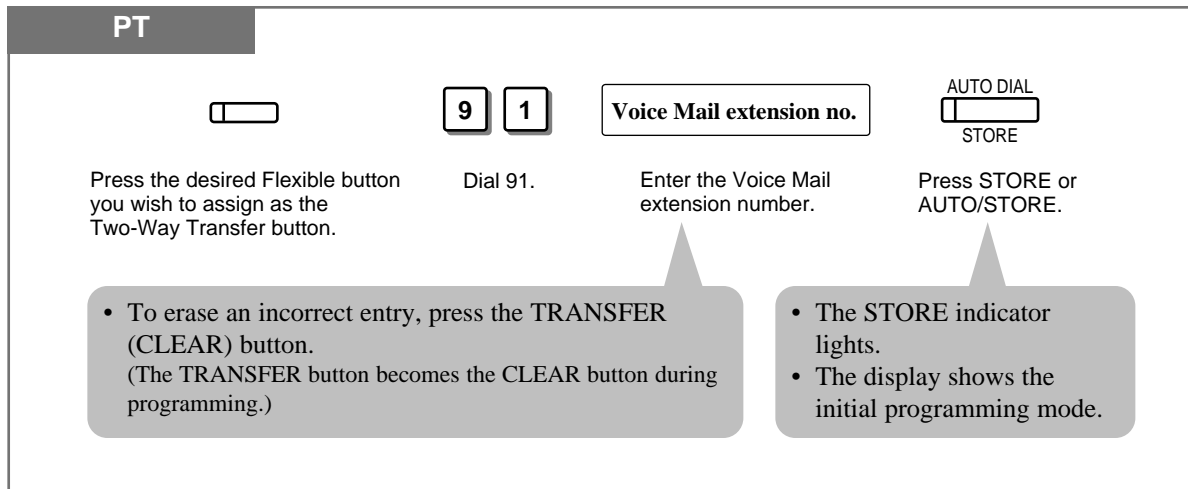

— After programming, set the MEMORY switch to “SET” or press the PROGRAM button.



- You cannot enter a non-existent extension number.
- A Voice Mail extension number must be assigned by System Programming.



- **Related Feature Reference**
 - 2.2 Telephone Features
 - “Two-Way Recording into Voice Mail”

Voice Mail (VM) Transfer Button (Assignment)

Allows you to assign a Flexible line key as the Voice Mail (VM) Transfer button.

— Be sure the handset is on the cradle and the SP-PHONE button is off. To program, set the MEMORY switch to “PROGRAM” or press the PROGRAM button.

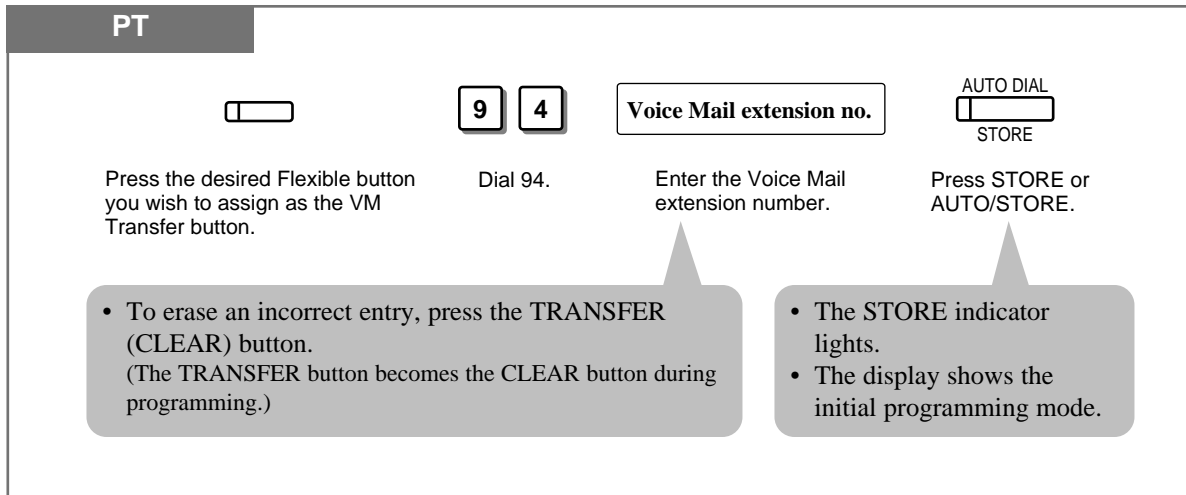

— After programming, set the MEMORY switch to “SET” or press the PROGRAM button.



- You cannot enter a non-existent extension number.
- A Voice Mail extension number must be assigned by System Programming.



- **Related Feature Reference**
2.2 Telephone Features
 “Voice Mail Transfer”

2.1 Proprietary Telephone Settings

Live Call Screening Mode Set

Assign whether the recording message is monitored through the built-in speaker (Hands-free mode) or an alert tone is sent (Private mode) while incoming callers are leaving a message.

— Be sure the handset is on the cradle and the SP-PHONE button is off. To program, set the MEMORY switch to “PROGRAM” or press the PROGRAM button.

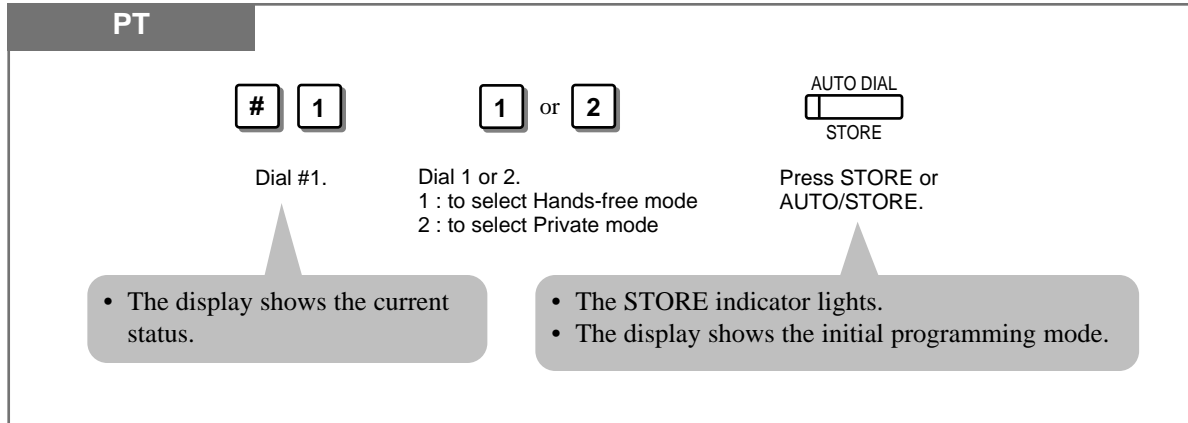

— After programming, set the MEMORY switch to “SET” or press the PROGRAM button.



- The default is the “Hands-free” mode.



- **Related Feature Reference**
 - 2.2 Telephone Features
 - “Live Call Screening (LCS)”

Live Call Screening (LCS)

While a caller is leaving a message in your mailbox, you can monitor the message. If desired, you can answer the call while monitoring. There are 2 methods available. In both modes, when you are having a conversation, you will hear a Call Waiting tone if Call Waiting has been enabled.

Hands-free Mode: You can monitor a message automatically through the telephone speaker at the same time.

Private Mode: You will hear an alert tone while the caller is leaving a message.

Preparation

- Assign the Live Call Screening (LCS) button
- Select the mode, either Hands-free or Private
- Set the Password
- Set the LCS feature

Flowchart of the Live Call Screening (LCS) Feature

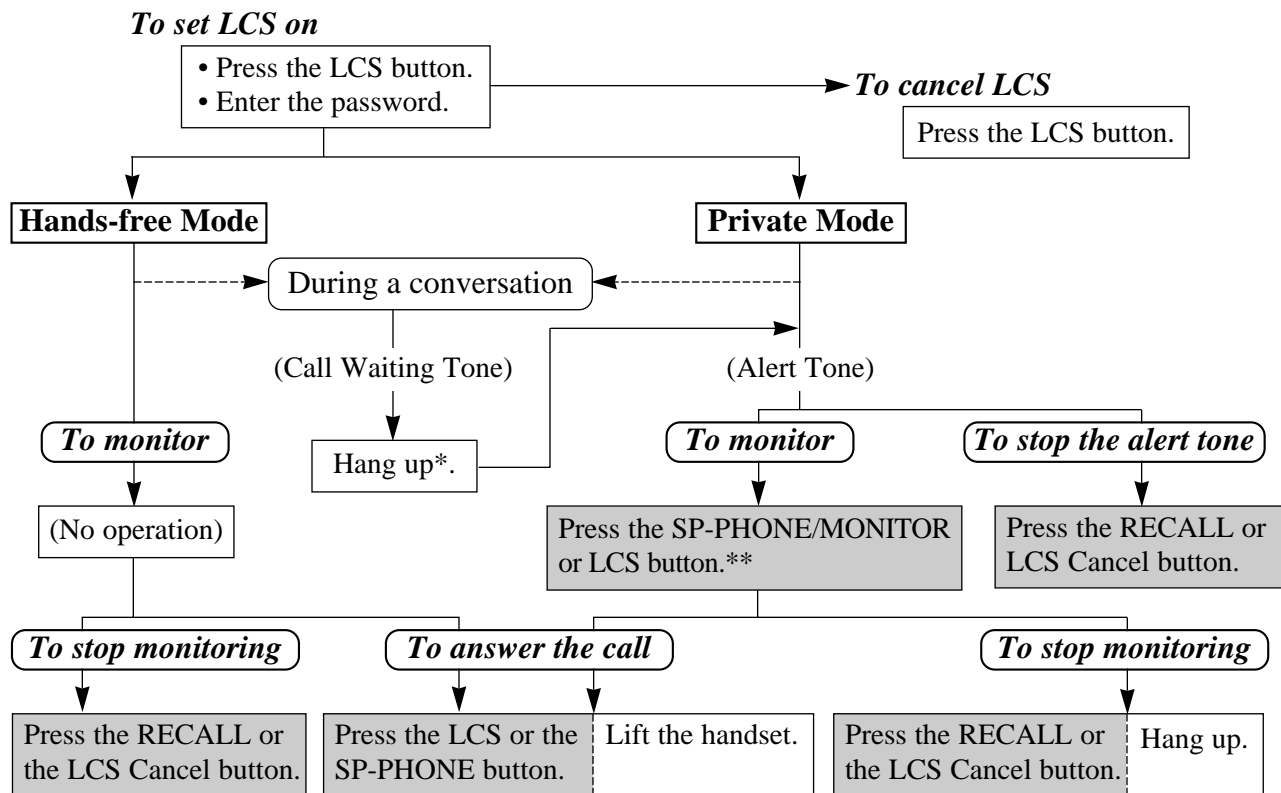

- *: To hold the current call temporarily, press the HOLD button. To return to the held call, press the line key whose indicator light flashes green slowly.
- **: If you lift the handset to monitor a message recording, the caller will be able to hear you. Even in this case, the message will still be recorded.
- The shaded areas are for the Hands-free operation.

2.2 Telephone Features

Setting the password

PT

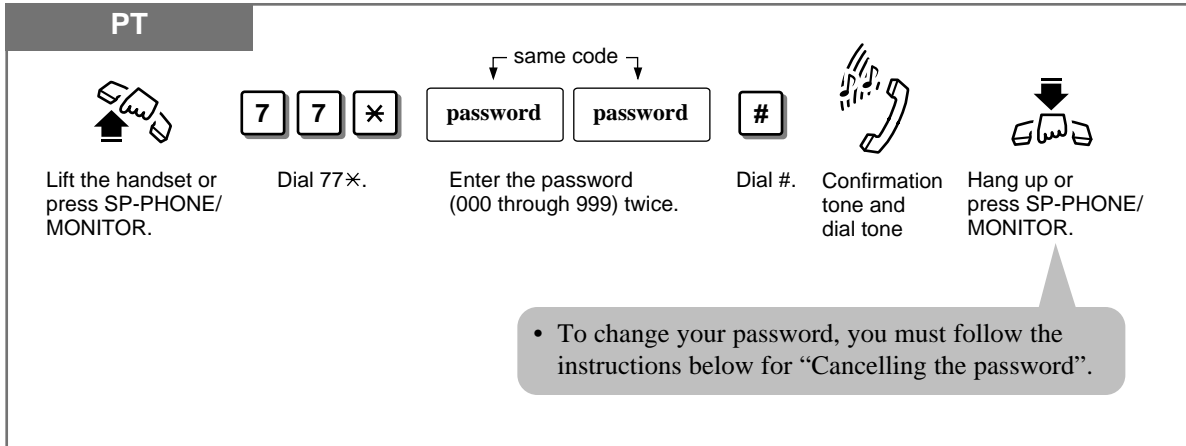

Lift the handset or press SP-PHONE/MONITOR.

Dial 77*.

Enter the password (000 through 999) twice.

Dial #.

Confirmation tone and dial tone

Hang up or press SP-PHONE/MONITOR.

- To change your password, you must follow the instructions below for “Cancelling the password”.

Cancelling the password

PT

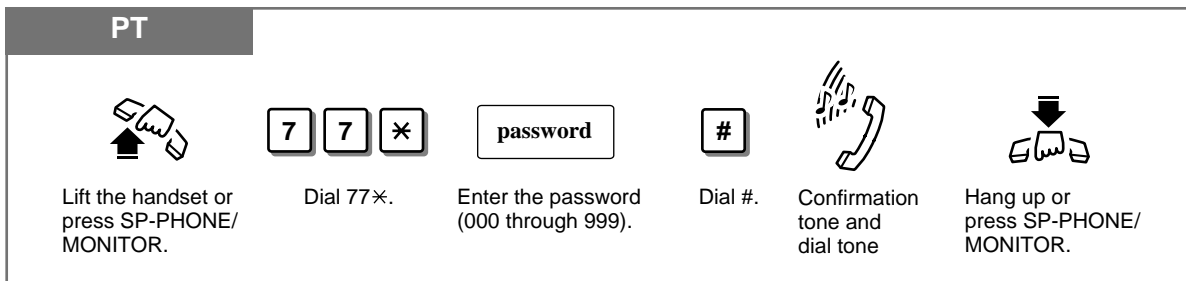

Lift the handset or press SP-PHONE/MONITOR.

Dial 77*.

Enter the password (000 through 999).

Dial #.

Confirmation tone and dial tone

Hang up or press SP-PHONE/MONITOR.

Setting Live Call Screening

PT

When the telephone is idle and on-hook.

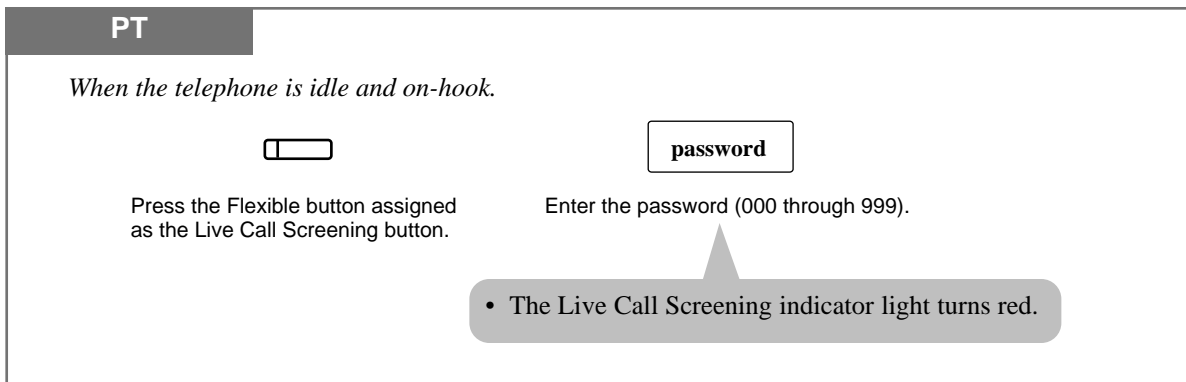

Press the Flexible button assigned as the Live Call Screening button.

Enter the password (000 through 999).

- The Live Call Screening indicator light turns red.

Canceling Live Call Screening

PT

When the telephone is idle and on-hook;



Press the Flexible button assigned as the Live Call Screening button.



- The Live Call Screening indicator light turns off.

In the Hands-free mode;

When callers are connected to your voice mailbox, the message recording is monitored automatically through your extension speaker. While monitoring in the Hands-free mode, the Live Call Screening indicator light flashes slowly.

Having a conversation with a party

PT

 or 

Lift the handset or press SP-PHONE, or press the Live Call Screening button.

- The Live Call Screening indicator light turns red from flashing slowly.
- In the Keep Recording mode, the Two-Way Record indicator turns on. Pressing the Two-Way Record button cancels the recording and the light turns off.

Stopping the monitoring

PT

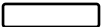
FLASH

or



Press FLASH or the Live Call Screening Cancel button.

- The Live Call Screening indicator light turns red from flashing slowly.

2.2 Telephone Features

In the Private mode;

Stopping the alert tone

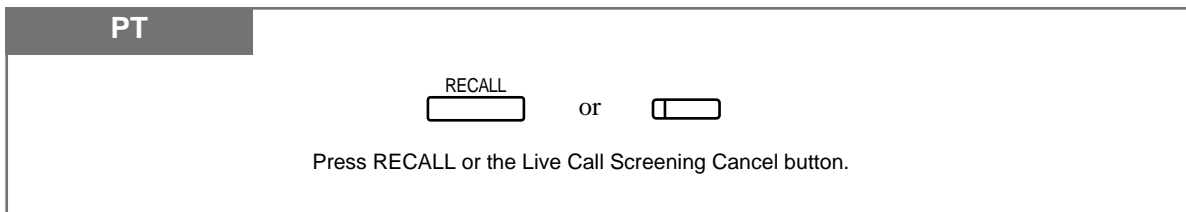

Monitoring the message recording

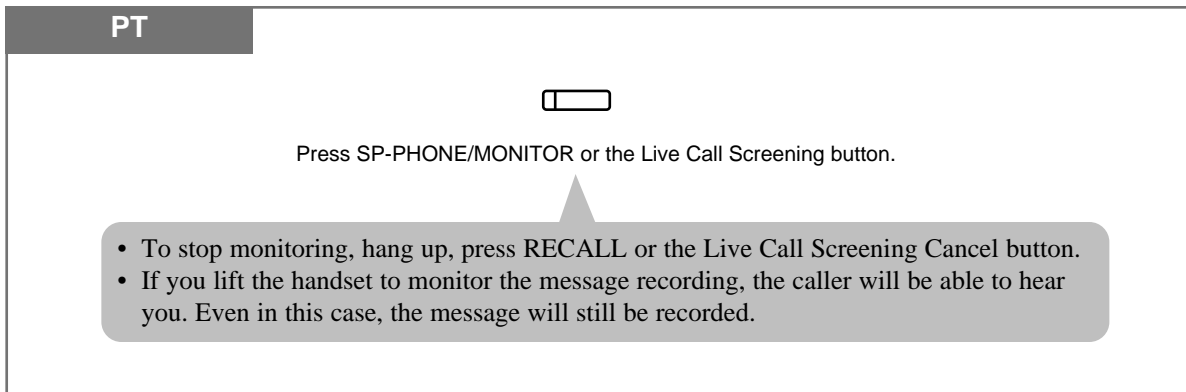

Talking to the party

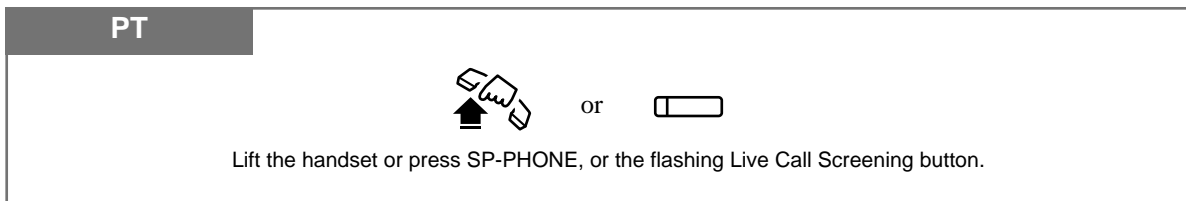

During a conversation with another party;

When the extension user is having a conversation, the Call Waiting tone will be heard if Call Waiting has been enabled. The Live Call Screening indicator light flashes.

— *If you want to terminate the current call*

Monitoring

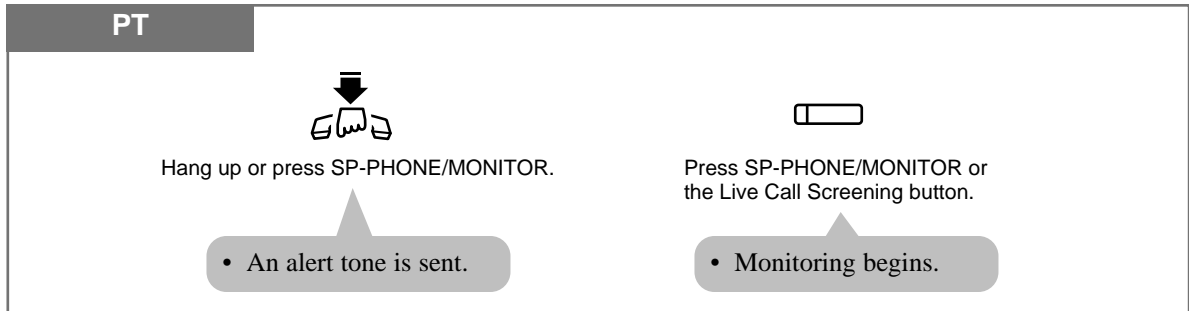

Having a conversation with a party

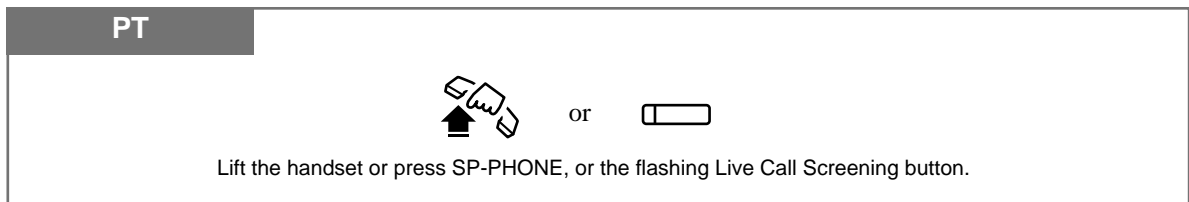

— *If you want to hold the current call*

Monitoring

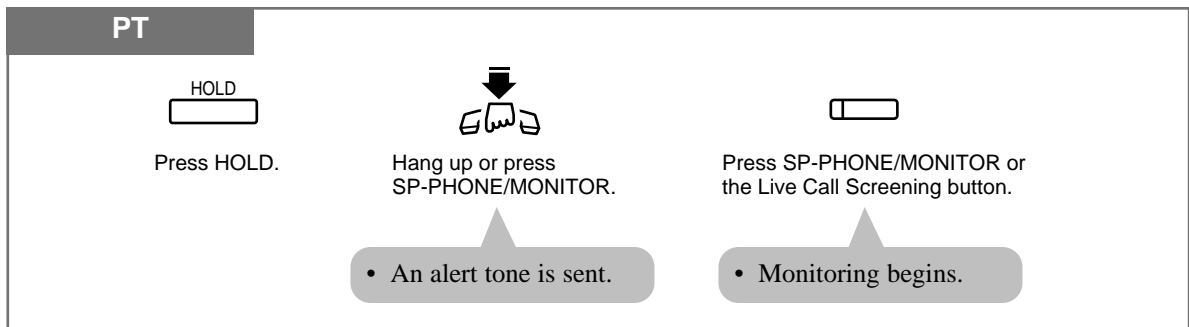

Having a conversation with a party

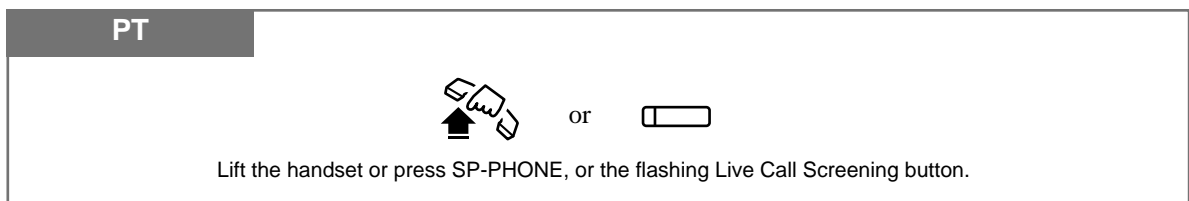

2.2 Telephone Features



- PT • A flexible line key or DSS button can be assigned as the Live Call Screening (LCS) button or the Live Call Screening (LCS) Cancel button.
- PT • The Live Call Screening indicator shows the feature status as follows:
 - Red (steady) The Live Call Screening mode is on.
 - Off The Live Call Screening mode is off.
 - Flashing green slowly . . . Live Call Screening is active.*
 - Flashing green rapidly . . . An alert tone is ringing.**
 - * The DSS button indicator flashes red slowly while Live Call Screening is active.
 - ** The DSS button indicator flashes red moderately while an alert tone is ringing.
- PT • The Two-Way Record indicator shows the feature status as follows:
 - On Recording the conversation.
 - Off Not recording.
- PT • The operator and the manager can clear a password at any extension.
- PT • During the Keep Recording mode, if you want to stop recording the conversation, press the Two-Way Recording button.
- PT • With a proprietary telephone with LCD, you can assign the password using the display operation.



- **Required Programming**

- 2.1 **Proprietary Telephone Settings**

- “Customising the Buttons on Your Telephone”, Live Call Screening (LCS) Button
 - Live Call Screening (LCS) Cancel Button
 - Two-Way Record Button

- “Live Call Screening Mode Set”

- **Related Feature References**

- 1.1 **System Features**

- Live Call Screening (LCS)

- 2.3 **Operator/Manager Service Features**

- “Live Call Screen Password Control”

- 2.4 **DSS Console Features**

- “Initial Settings”, Live Call Screening (LCS) Button Assignment

- Live Call Screening (LCS) Cancel Button Assignment

- Two-Way Record Button Assignment

Two-Way Recording into Voice Mail

Allows you to record a conversation into your mailbox or a specified mailbox.

Recording into your mailbox

PT

During a conversation



Press the Flexible button assigned as the Two-Way Record button.

- The Two-Way Record indicator light turns red.

Stopping Recording

PT



Press the Flexible button assigned as the Two-Way Record button.

- The Two-Way Record indicator light turns off.

Recording into another mailbox

PT

During a conversation



Press the Flexible button assigned as the Two-Way Transfer button.

extension number OR 

Enter an extension number or press the desired DSS.

- The Two-Way Transfer indicator light turns red.

Stopping Recording

PT



Press the Flexible button assigned as the Two-Way Transfer button.

- The Two-Way Record indicator light turns off.

2.2 Telephone Features



- PT • A flexible line key or DSS button can be assigned as the Two-Way Record button or the Two-Way Transfer button.
- PT • Pressing the Two-Way Record button sends an alarm tone, if an idle Voice Mail port is not available.
- PT • Pressing the Two-Way Transfer button followed by an extension number sends an alarm tone, if an idle Voice Mail port is not available.



- **Required Programming**

- **2.1 Proprietary Telephone Settings**

- “Customising the Buttons on Your Telephone”, Two-Way Record Button
Two-Way Transfer Button

- **Related Feature References**

- **1.1 System Features**

- Two-Way Recording into Voice Mail

- **2.4 DSS Console Features**

- “Initial Settings”, Two-Way Record Button Assignment
Two-Way Transfer Button Assignment

Voice Mail Integration for KX-TVP50

Allows you to forward your calls to your mailbox in a Panasonic Voice Processing System (VPS) equipment (KX-TVP50). A caller can leave a message in your mailbox. If you use a proprietary telephone which has a MESSAGE button, the button light will turn on to let you know you have messages. If you use a single line telephone, dial tone 3 will let you know you have messages when you go off-hook.

Setting Call Forwarding destination to Voice Mail

PT and SLT

Lift the handset or press SP-PHONE/MONITOR.

For a PT: Press FWD/DND.
For an SLT: Dial 71.

Dial the Call Forwarding number.
1: Call Forwarding — All Calls
2: Call Forwarding — Busy/No Answer

Enter the Voice Mail extension number.

Dial #.

Confirmation tone and dial tone

Hang up or press SP-PHONE/MONITOR.

- You may press the flexible button assigned as the FWD/DND button instead.
- Calls directed to you are automatically forwarded to your mailbox.
- Callers can leave their messages in the mailbox, according to the Voice Mail guidance.

Cancelling Call Forwarding destination to Voice Mail

PT and SLT

Lift the handset or press SP-PHONE/MONITOR.

For a PT: Press FWD/DND.
For an SLT: Dial 71.

Dial 0.

Dial #.

Confirmation tone and dial tone

Hang up or press SP-PHONE/MONITOR.

- You may press the flexible button assigned as the FWD/DND button instead.

2.2 Telephone Features

Listening to a stored message

You can listen to the messages stored in your mailbox easily. There are 2 operations to play back messages.

Using the Message Waiting (MESSAGE) button

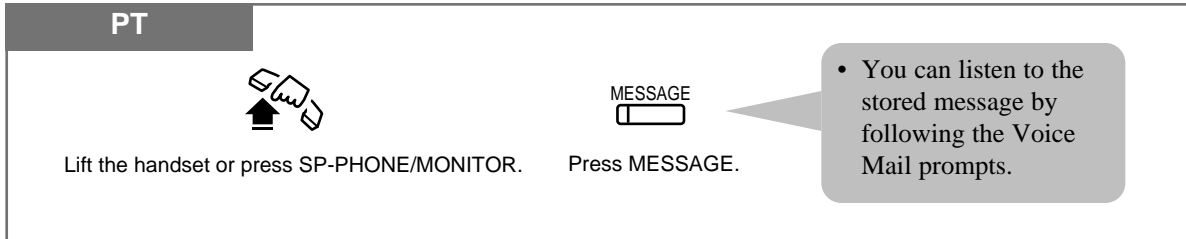

By manual dialling

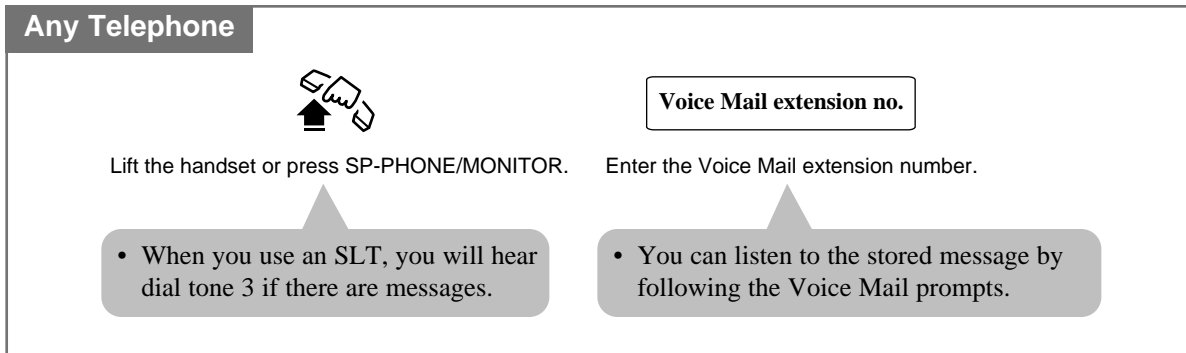

- Voice Mail can be assigned as the destination for the following features.
 - a) Call Forwarding — All Calls
 - b) Call Forwarding — Busy/No Answer
 - c) Intercept Routing
 - Outside callers can leave messages in your mailbox. When an incoming outside call is received, the operator answers the call and transfers it to your extension.
 - **If you set the “Call Forwarding” feature at the Voice Mail destination;**
The call will be forwarded to Voice Mail automatically.
 - **If you do not set the “Call Forwarding” feature;**
The call will return to the operator. Then the operator will transfer the call to Voice Mail.
 - An incoming call via DISA is automatically transferred to Voice Mail when the destination extension is assigned to “Intercept” and a Voice Mail extension is assigned as the Intercept Routing destination.
 - You can also transfer the received outside calls to specific mailboxes so that callers can leave messages by the Voice Mail Transfer feature.
- PT** • A flexible button can be assigned as the FWD/DND button.
- PT** • If you set the Call Forwarding — Busy/No Answer feature, the FWD/DND button light will keep flashing. To stop this flashing, go off-hook and dial 716#.
- SLT** • You will hear dial tone 3 if there are messages in your mailbox when you go off-hook. When you access Voice Mail, you have to listen to all of the new messages. If you do not listen to all of the messages, dial tone 3 will be eliminated and you will not know there are messages left in your mailbox the next time you go off-hook.



- **Required Programming**

- Section 1, Operations Operating Instructions

- 1.2 Proprietary Telephone Settings**

- “Customising the Buttons on Your Telephone”, FWD/DND (Forward/Do Not Disturb)

- Button

- Restoring the MESSAGE Button

- **Related Feature References**

- 1.1 System Features**

- Voice Mail Integration for KX-TVP50

- Section 3, Features **Installation Manual**

- Call Forwarding

- Intercept Routing

2.2 Telephone Features

Voice Mail Transfer

You can transfer outside calls to the Voice Processing System so that callers can leave their messages in a desired extension mailbox. When you transfer an outside call to the designated extension;

— **If the extension has set the “Call forwarding” function whose destination is Voice Mail;**

The call will be forwarded to Voice Mail.

— **If the extension has not set the “Call forwarding” function;**

The call will return to you. You can then transfer the call to Voice Mail by simply following the operation below.

PT

If the call returns to you

 extension number or

Press the Flexible button assigned as the Voice Mail (VM) Transfer button. Enter an extension number or press DSS.

- The call will be transferred to Voice Mail.
- The caller can leave the message according to the Voice Mail guidance.
- You cannot enter your own extension number.



PT • A flexible button or DSS button can be assigned as the Voice Mail (VM) Transfer button.



- **Required Programming**

- 2.1 **Proprietary Telephone Settings**

- “Customising the Buttons on Your Telephone”, Voice Mail (VM) Transfer Button

- **Related Feature References**

- 1.1 **System Features**

- Voice Mail Integration for KX-TVP50

- 2.2 **Telephone Features**

- “Voice Mail Integration for KX-TVP50”

- 2.4 **DSS Console Features**

- “Initial Settings”, Voice Mail (VM) Transfer Button Assignment

Live Call Screening Password Control

The operator or manager can clear the Live Call Screening password on any extension.

Clearing the Live Call Screening password

— Be sure the handset is on the cradle and the SP-PHONE button is off. To program, set the MEMORY switch to “PROGRAM” or press the PROGRAM button.

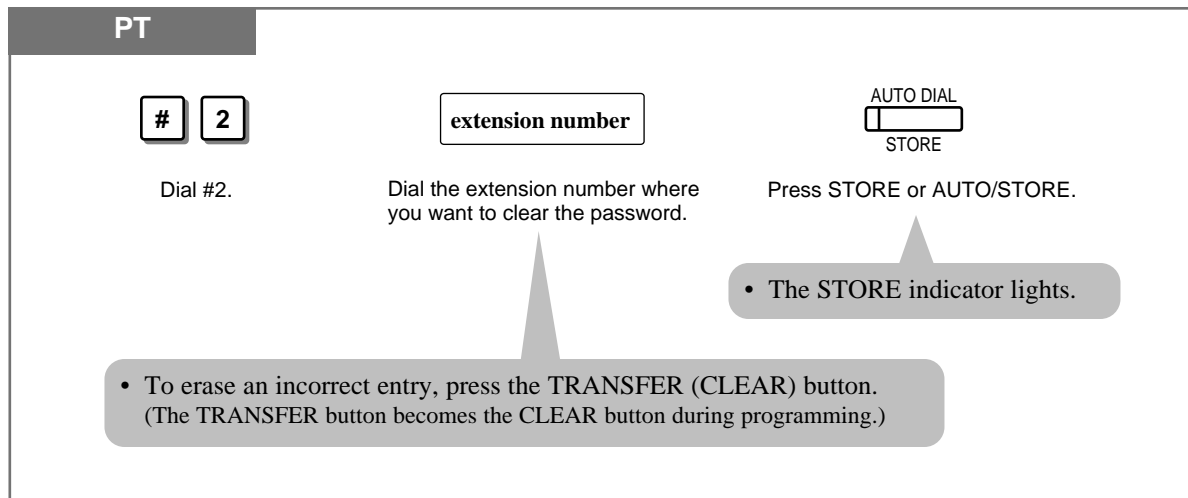

— After programming, set the MEMORY switch to “SET” or press the PROGRAM button.



- If the extension user forgets their pre-set password, they can ask the operator or manager to clear the password.



- **Related Feature Reference**
 - 1.1 System Features
 - Live Call Screening (LCS)
 - 2.2 Telephone Features
 - “Live Call Screening (LCS)”

2.4 DSS Console Features

Initial Settings



- DSS buttons can be changed to any of the following feature buttons by Initial Settings.
 - a) Live Call Screening (LCS) Button
 - b) Live Call Screening (LCS) Cancel Button
 - c) Two-Way Record Button
 - d) Two-Way Transfer Button
 - e) Voice Mail (VM) Transfer Button

Live Call Screening (LCS) Button Assignment

You can assign a DSS button as the Live Call Screening (LCS) button.

- Be sure the handset is on the cradle and the SP-PHONE button is off. To program, set the MEMORY switch to “PROGRAM” or press the PROGRAM button.

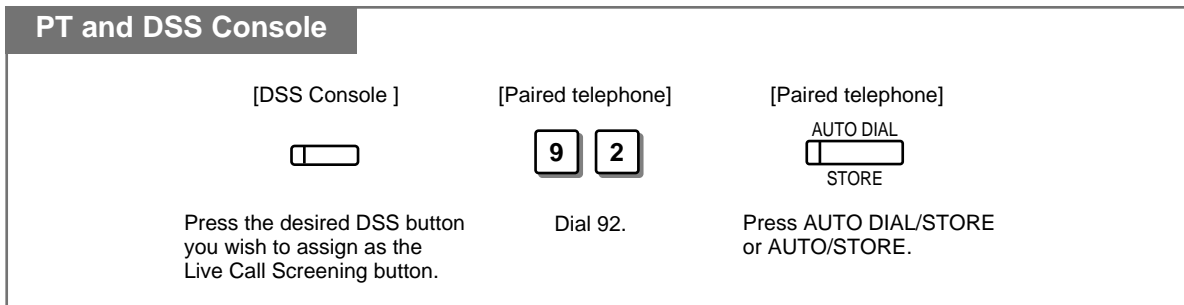

- After programming, set the MEMORY switch to “SET” or press the PROGRAM button.

Live Call Screening (LCS) Cancel Button Assignment

You can assign a DSS button as the Live Call Screening (LCS) Cancel button.

- Be sure the handset is on the cradle and the SP-PHONE button is off. To program, set the MEMORY switch to “PROGRAM” or press the PROGRAM button.

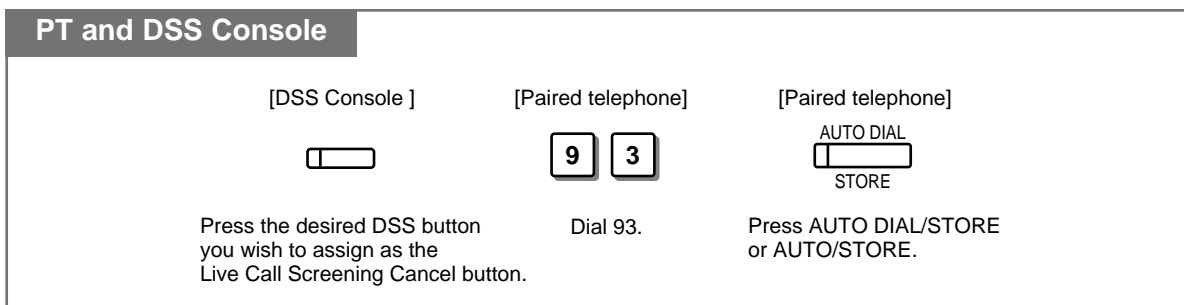

- After programming, set the MEMORY switch to “SET” or press the PROGRAM button.

Two-Way Record Button Assignment

You can assign a DSS button as the Two-Way Record button.
This allows you to record a conversation into your voice mailbox.

— Be sure the handset is on the cradle and the SP-PHONE button is off. To program, set the MEMORY switch to “PROGRAM” or press the PROGRAM button.

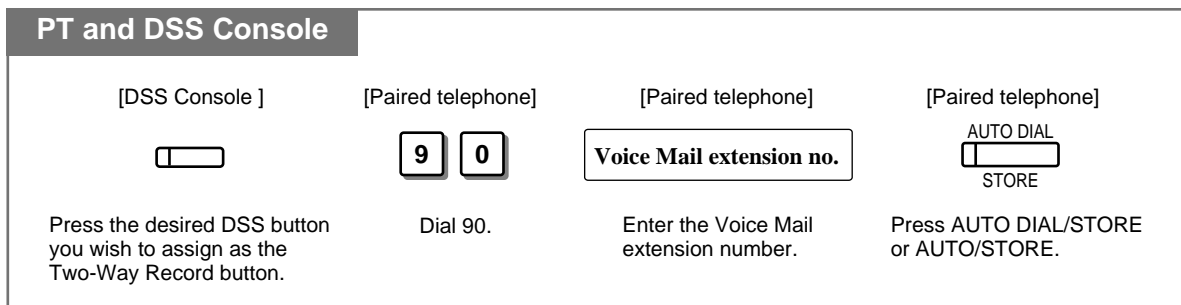

— After programming, set the MEMORY switch to “SET” or press the PROGRAM button.

Two-Way Transfer Button Assignment

You can assign a DSS button as the Two-Way Transfer button.
This allows you to record a conversation into a desired mailbox.

— Be sure the handset is on the cradle and the SP-PHONE button is off. To program, set the MEMORY switch to “PROGRAM” or press the PROGRAM button.

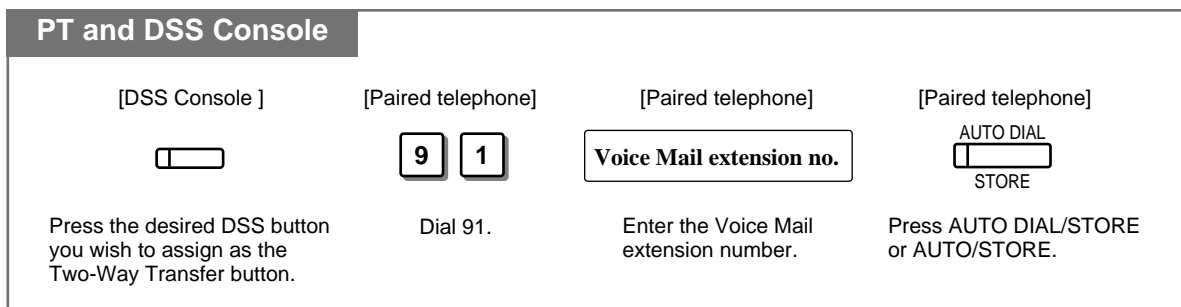





— After programming, set the MEMORY switch to “SET” or press the PROGRAM button.

2.4 DSS Console Features

Voice Mail (VM) Transfer Button Assignment

You can assign a DSS button as the Voice Mail (VM) Transfer button.

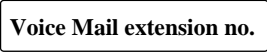
— Be sure the handset is on the cradle and the SP-PHONE button is off. To program, set the MEMORY switch to “PROGRAM” or press the PROGRAM button.

PT and DSS Console			
[DSS Console] 	[Paired telephone] 	[Paired telephone] 	[Paired telephone] 
Press the desired DSS button you wish to assign as the VM Transfer button.	Dial 94.	Enter the Voice Mail extension number.	Press AUTO DIAL/STORE or AUTO/STORE.

— After programming, set the MEMORY switch to “SET” or press the PROGRAM button.

Due to the Trilingual Selection Feature, you can select the display in English, Spanish or Portuguese by System Programming. The left part is the English display and the right part is the Spanish display.

ENGLISH DISPLAY	SPANISH DISPLAY	DESCRIPTION
LCS	Monitor.Mensajes	Completed setting “Live Call Screening (LCS)”.
LCS Cancel	Canc.Monit.Mens.	Cancelled “Live Call Screening (LCS)”.
Password:123	Clave :123	Completed setting the LCS password. — “Live Call Screening (LCS)”
Password Cancel	Cancel.Codigo	Cancelled the LCS password. — “Live Call Screening (LCS)”

Panasonic Business Systems U.K.

Panasonic House, Willoughby Road, Bracknell, Berkshire RG12 8FP

Copyright:

This manual is copyrighted by Kyushu Matsushita Electric Co., Ltd. (KME). Under the applicable copyright laws, this manual may not be reproduced in any form, in whole or part, without the prior written consent of KME and its licensee.

© 2000 Kyushu Matsushita Electric Co., Ltd. All Rights Reserved.